

Biquads Based on Single Negative Impedance Converter Implemented by Classical Current Conveyor

Tomáš DOSTÁL, Vladimír AXMAN

Dept. of Radio Electronics, Brno University of Technology, Purkyňova 118, 612 00 Brno, Czech Republic

dostal@feec.vutbr.cz

Abstract. The paper deals with continuous-time ARC biquadratic (second-order) filters based on the single classical three-port current conveyors, so called second generation CC II. A unique application of the CC II is discussed, when the terminals Y and Z are connected together. Using this way a negative impedance converter is obtained as a suitable building block in synthesis of several biquads, including notch filters.

Keywords

Analogue circuits, active RC filters, biquads, current conveyors, negative impedance converters.

1. Introduction

It is well known that precisely tailored frequency filters can be produced with standard operational amplifiers [8], but for audio application only. In higher frequency range it is better to use some of modern active functional blocks. Such versatile and powerful building blocks are the current conveyors (CC) [6]. Continuous-time active RC filters based on the CC have recently found attractive considerable attention. This stems from inherent advantages of the CC circuits, namely low supply voltages and power, current operational mode possibility, well-developed IC topology and particularly a frequency range of the signal processing which can be higher than with circuits with the standard operational amplifiers. Classical three-port current conveyors, often denoted as CC II (second-generation), were introduced by Smith and Sedra [1]. Since their introduction (1970) the CC II have led to a great number of applications in signal processing circuits, especially many oscillators and ARC filters have been given, for examples see references [1] - [7]. In case of the biquadratic (second-order) filters, mostly as basic all-pole filters, namely low-pass (LP), band-pass (BP), high-pass (HP) type only, less commonly as notch biquads, having transmission zeros, namely as band-reject filters (BR), low-pass notch (LPN) and high-pass notch (HPN) filters, what will be given in this paper. The synthesis of the conveyor based circuits is still an active topic. A unique systematic design procedure is presented, which is based on generalized autonomous

network corresponding with suitable characteristic equation, as it was in detail shown in [4].

2. Three-Port Current Conveyors

It is well known that the definition relations of the CC II (+) port variables in Fig. 1 are

$$v_x = A \cdot v_y, \quad i_z = B \cdot i_x, \quad i_y = 0. \quad (1)$$

There ideally $A = B = 1$. Thus the Y port acts as high-impedance terminal and copies the voltage at the X. The X port is a low-impedance terminal and copies (conveys) the current at the port Z. Note that in this type CC II there is the absence of the current I_Y (1) and the current I_Z flows in the same direction of the current I_X (Fig. 1), if it is opposite, the conveyor is of other type, namely CC II (-).

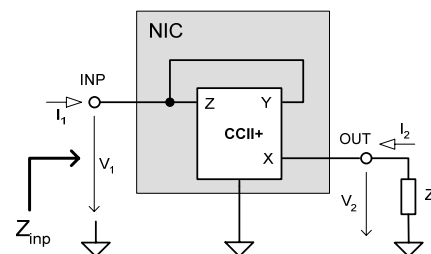

Fig. 1. Negative impedance converter using the CC II (+).

3. Negative Impedance Converter from Conveyor CC II (+)

A unique application of the CC II (+) is obtained (firstly reported in [6]), if the terminals Y and Z are connected together (Fig.1), than

$$v_x = v_y = v_z, \quad i_z = i_x, \quad i_y = 0. \quad (2)$$

This two-port represents an *impedance converter* (IC) with the following relations between external port variables

$$v_1 = v_2, \quad i_1 = i_2. \quad (3)$$

The impedance transfer is

$$Z_{\text{inp}} = -Z_L \quad (4)$$

and the IC is *negative* (NIC). Changing the input and output the same relations (3), (4) can be obtained [9], the NIC is reciprocal. This NIC with CC II (+) (Fig. 1) will be used down as a basic building block in our synthesis of the several biquads as follows.

4. Structures of Biquads Using Negative Impedance Converter

To design a biquadratic ARC filter with the NIC, the procedure from [4] can be used. One suitable general structure (GBS1) of the biquad, using single NIC and four passive (*RC*) admittances, is shown in Fig. 2a. There the NIC separates two passive twoports and the impedance transformation improves the property of the whole biquad (increases the Q factor). The structure GBS-1 (Fig. 2a) holds the voltage transfer function in following general form

$$K(s) = \frac{Y_1 Y_3 A}{Y_1 Y_3 + Y_1 Y_4 + Y_2 Y_3 + Y_2 Y_4 - Y_3 Y_4 AB} \tag{5}$$

This formula is resulting from a routine of symbolical nodal analysis, done by the computer tool SNAP.

The second suitable general structure (GBS-2) of the biquad with five passive admittances and one NIC is given in Fig. 2b. There is a feedback by the admittance Y_5 . The transfer function of this structure (Fig. 2b) is resulting (by the program SNAP) in a little complicated symbolic formula

$$K = \frac{Y_2 Y_5 + Y_1 Y_5 + Y_1 Y_3 - Y_3 Y_5}{Y_1 Y_3 + Y_1 Y_4 + Y_1 Y_5 + Y_2 Y_3 + Y_2 Y_4 + Y_2 Y_5 - Y_3 Y_4 - Y_3 Y_5} \tag{6}$$

Note that for simplification the ideal CC II (+) is assumed, so $A = B = 1$.

The other two given structures are modifications of the GBS-2 only. The GBS-3 has the admittance Y_4 (Fig. 2b) omitted. Then the voltage transfer function (6) has the simplified form

$$K = \frac{Y_2 Y_5 + Y_1 Y_5 + Y_1 Y_3 - Y_3 Y_5}{Y_1 Y_3 + Y_1 Y_5 + Y_2 Y_3 + Y_2 Y_5 - Y_3 Y_5} \tag{7}$$

The structure GBS-4 has also $Y_4 = 0$ and modified Y_2 as a parallel connection of two admittances $Y_2 = Y_{2A} + Y_{2B}$.

The transfer function of the general structure GBS-5 (Fig. 2c) is more complicated, the numerator for the case of $A = B = 1$ is given by (8) and denominator by (9)

$$N(s) = Y_1 Y_2 Y_5 + Y_1 Y_3 Y_5 + Y_1 Y_2 Y_4 - Y_1 Y_4 Y_5, \tag{8}$$

$$D(s) = Y_1 Y_2 Y_4 + Y_1 Y_2 Y_5 + Y_1 Y_3 Y_4 + Y_1 Y_3 Y_5 + Y_2 Y_3 Y_4 + Y_2 Y_3 Y_5 + Y_3 Y_5 Y_4 - Y_1 Y_4 Y_5 \tag{9}$$

Substituting a voltage buffer (VCVS) in the GBS-5 as shown in Fig. 2d the last suitable general structure GBS-6 is obtained. Then the transfer function of the GBS-6 is simpler, namely the denominator is

$$D(s) = Y_1 Y_2 Y_4 + Y_1 Y_2 Y_5 + Y_1 Y_3 Y_4 + Y_1 Y_3 Y_5 + Y_2 Y_3 Y_4 + Y_2 Y_3 Y_5 - Y_1 Y_4 Y_5 \tag{10}$$

and the numerator keeps the previous form (8). A suitable choosing of the admittances Y_k (R or C) for realization of the several functional biquads will be shown down. Note that other modification of this general structure with single NIC can be possible.

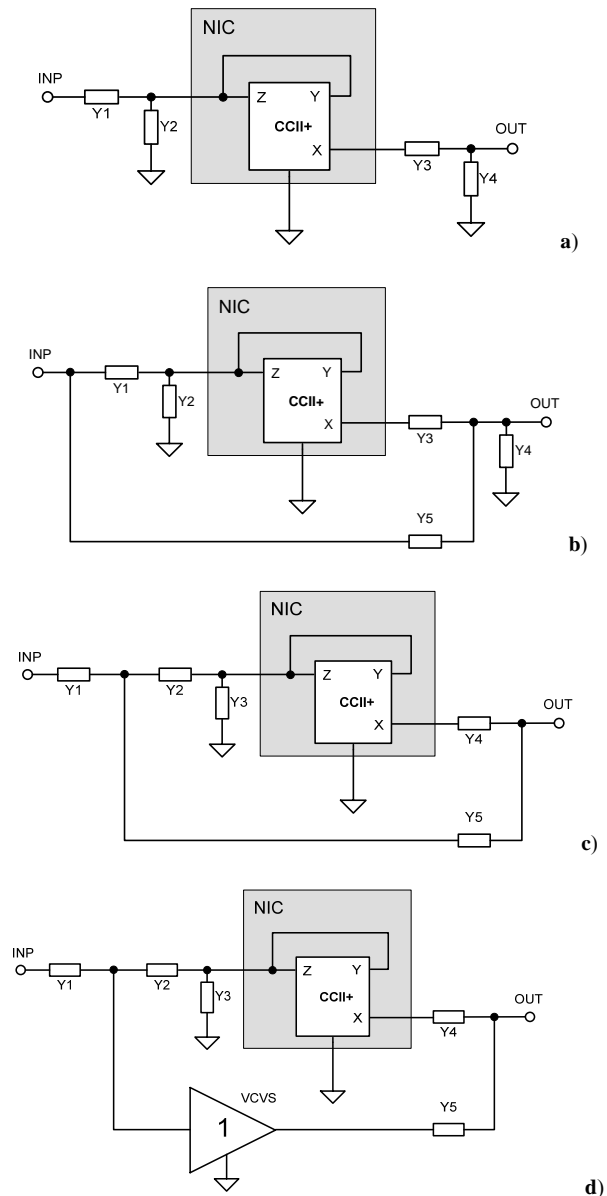

Fig. 2. General biquad structures using the NIC: a) structure GBS-1, b) structure GBS-2, c) structure GBS-5, d) structure GBS-6.

5. Low-Pass All-Pole Biquad with NIC

From the general structures given above (Fig. 2) we can build a frequency filters, so that we choose the admittances Y_k as a single resistor R_k or capacitor C_k to obtain the desired form of the transfer function. For a low-

pass all-pole biquad the structure GBS-1 (Fig. 2a) is most suitable, choosing the concrete admittances as shown in Fig. 3. In this case and if $A = B = 1$ the transfer function is

$$K(s) = \frac{G_1 G_2}{s^2 C_1 C_2 + s[C_2(G_1 - G_2) + C_1 G_2] + G_1 G_2}. \quad (11)$$

From the denominator of the $K(s)$ (11) a frequency of poles (or cut-off -3 dB frequency) (12) and a quality factor of poles (13) have been derived in following forms

$$\omega_{-3dB} = \omega_p = \sqrt{\frac{G_1 G_2}{C_1 C_2}}, \quad (12)$$

$$Q_p = \frac{\sqrt{C_1 C_2 G_1 G_2}}{C_1 G_2 + C_2(G_1 - G_2)}. \quad (13)$$

These equations can be used to design the certain low-pass biquad. The optimal case is if $C_1 G_2 = C_2 G_1$. Usually $C_1 = C_2 = C$, then the design equations are simpler and the quality factor is proportional to the resistor spread only

$$\omega_p = \frac{1}{C} \sqrt{\frac{1}{R_1 R_2}}, \quad Q_p = \sqrt{\frac{R_1}{R_2}}. \quad (14), (15)$$

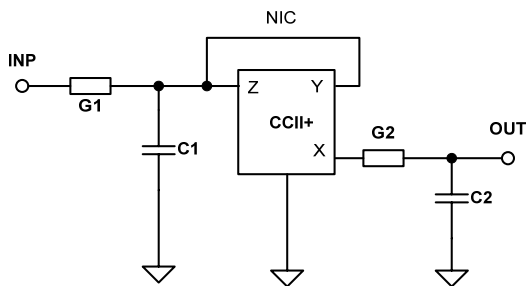

Fig. 3. Low-pass all-pole biquad using the NIC.

6. High-Pass Biquad Using NIC

The HP biquad can be obtained from Fig. 3 using the known LP \leftrightarrow HP transformation [7] replacing $R_k \leftrightarrow C_k$. The resulting circuit diagram is shown in Fig. 4. This circuit holds the transfer function with the same denominator

$$K(s) = \frac{s^2 C_1 C_2}{s^2 C_1 C_2 + s[C_2(G_1 - G_2) + C_1 G_2] + G_1 G_2}, \quad (16)$$

the same equations for the frequency (12) and the quality factor (13) of the poles as was given above. For the optimal design the equations (14), (15) can also be used.

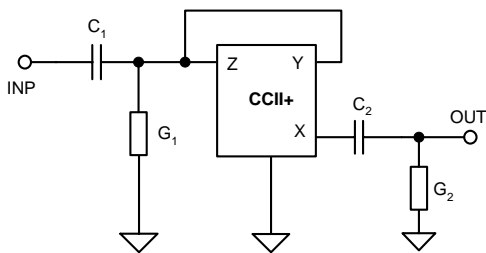

Fig. 4. High-pass biquad using the NIC.

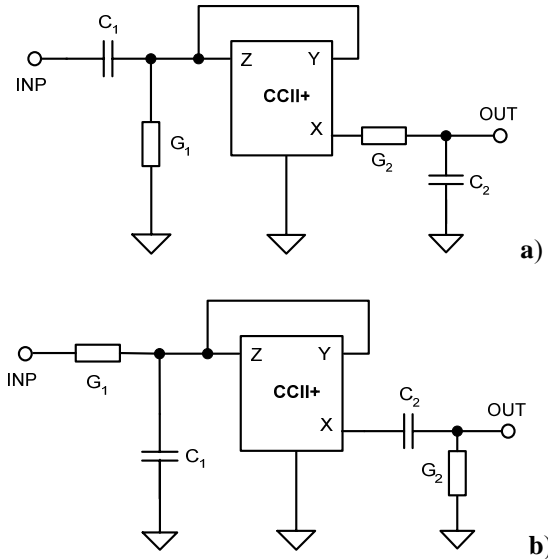

Fig. 5. Band-pass biquad using the NIC: a) variant BP-1, b) variant BP-2.

7. Band-Pass Biquad Using NIC

The structure GBS-1 (Fig. 2a) is suitable for the BP biquad, too, choosing the admittances as shown in Fig. 5. Symbolical analysis of the circuit BP-1 in Fig. 5a, by the tool SNAP, is resulting in the voltage transfer function

$$K(s) = \frac{s C_1 G_2}{s^2 C_1 C_2 + s[C_2(G_1 - G_2) + C_1 G_2] + G_1 G_2}. \quad (17)$$

The other modification BP-2 in Fig. 5b was obtained interchanging $R_k \leftrightarrow C_k$. Then the NIC separates the first subcircuit LP-RC and second one HP-RC. The transfer function has other numerator only

$$K(s) = \frac{s C_2 G_1}{s^2 C_1 C_2 + s[C_2(G_1 - G_2) + C_1 G_2] + G_1 G_2}. \quad (18)$$

To design the BP biquads all notes given above can be used too (see section 5).

8. Band-Reject Biquad Using NIC

The function of the band-reject filter (BR) is to attenuate a finite band while passing both lower and higher frequencies. A second order transfer function that realizes the BR has following general form

$$K(s) = \frac{U_{out}}{U_{in}} = K_0 \frac{s^2 + \frac{\omega_N}{Q_N} s + \omega_N^2}{s^2 + \frac{\omega_p}{Q_p} s + \omega_p^2}, \quad (19)$$

where $\omega_N = \omega_p$ to achieve a symmetric BR gain response and usually $Q_N \rightarrow \infty$ (the zeros are on the imaginary axis). Then the attenuation is infinite at ω_N and Q_p controls the sharpness of the notch.

The BR biquad can be realized by the structure GBS-3 (Fig. 2b with the admittance $Y_4 = 0$). The two possible network realizations of the BR biquad are given in Fig. 6.

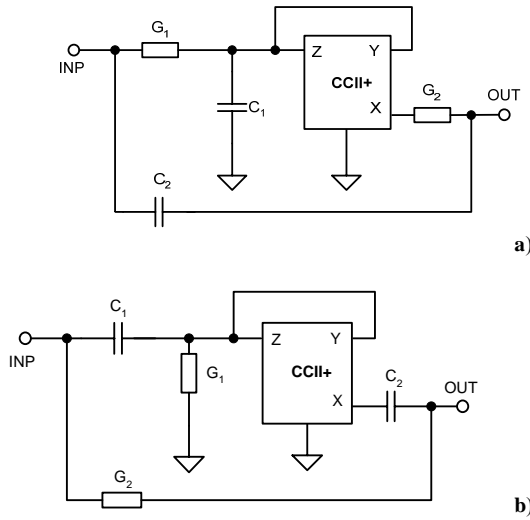

Fig. 6. Band-reject biquad using the NIC: **a)** variant BR-1, **b)** variant BR-2.

The *variant BR-1* in Fig. 6a holds the following transfer function

$$K(s) = \frac{s^2 C_1 C_2 + s(C_2(G_1 - G_2)) + G_1 G_2}{s^2 C_1 C_2 + s(C_2(G_1 - G_2) + C_1 G_2) + G_1 G_2} \quad (20)$$

For the desired position of the zeros, or for $Q_N \rightarrow \infty$ in the eq. (19), the condition $G_1 = G_2 = G$ must be valid and then the transfer function (20) has the simplest form

$$K(s) = \frac{s^2 C_1 C_2 + G^2}{s^2 C_1 C_2 + s C_1 G + G^2} \quad (21)$$

Comparing (21) and (19) the design equations are done, namely the band-reject or zero and pole frequency

$$\omega_{BR} = \omega_N = \omega_p = \frac{1}{R} \sqrt{\frac{1}{C_1 C_2}} \quad (22)$$

and the quality factor of the poles is proportional to the capacitor spread only

$$Q_p = \sqrt{\frac{C_2}{C_1}} \quad (23)$$

The dual *variant BR-2* (changing $R \leftrightarrow C$) in Fig. 6b has similar properties, following the dual condition $C_1 = C_2 = C$ and the design equations

$$\omega_{BR} = \omega_N = \omega_p = \frac{1}{C} \sqrt{\frac{1}{R_1 R_2}} \quad (24)$$

$$Q_p = \sqrt{\frac{R_1}{R_2}} \quad (25)$$

9. Low-Pass Notch Biquad Using NIC

The low-pass notch biquad (LPN) can be based on the general structure GBS-2 (Fig. 2b), adding in the variant *BR-1* (Fig. 6a) one other capacitor ($Y_4 = sC_3$), as shown in Fig. 7a. Assuming the condition $G_1 = G_2 = G$ the general transfer function (6) is modified in this concrete form

$$K(s) = \frac{s^2 C_1 C_2 + G^2}{s^2 C_1 (C_2 + C_3) + s C_1 G + G^2} \quad (26)$$

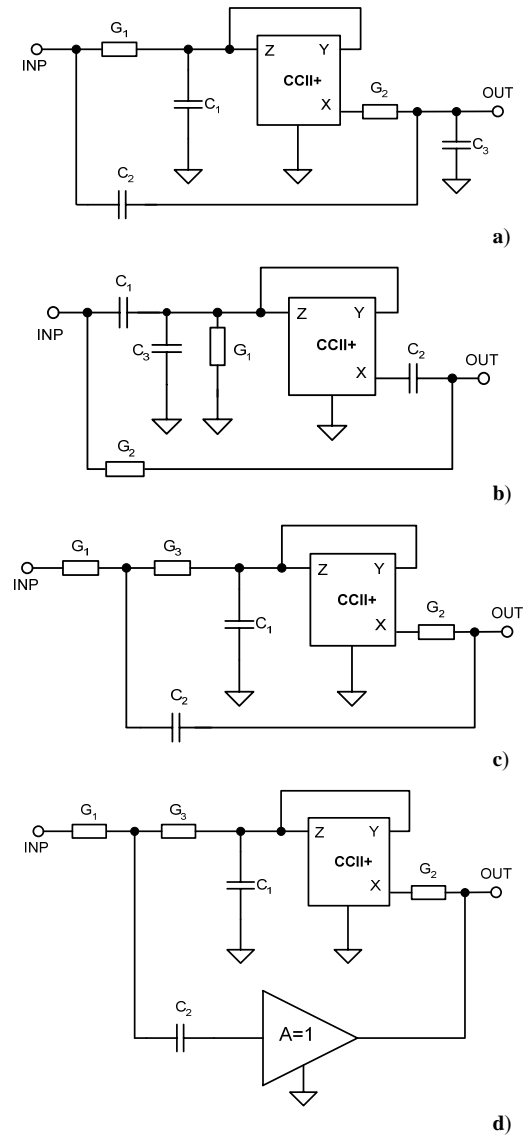

Fig. 7. Low-pass notch biquad based on the NIC: **a)** variant LPN-1, **b)** variant LPN-2, **c)** variant LPN-3, **d)** variant LPN-4.

Then the *variant LPN-1* (Fig. 7a) holds the following parameters of the poles and zeros:

$$\omega_p = \frac{1}{R} \sqrt{\frac{1}{C_1 C_2}} \quad , \quad \omega_N = \omega_p \sqrt{\frac{C_2 + C_3}{C_2}} \quad (27), (28)$$

$$Q_P = 2\sqrt{\frac{C_2 + C_3}{C_1}}, \quad Q_N \rightarrow \infty. \quad (29), (30)$$

The second *variant LPN-2* is based on the general structure GBS-4, choosing the concrete admittances as shown in Fig. 7b. There the admittance Y_2 is modified as a parallel connection of two admittances ($Y_2 = Y_{2A} + Y_{2B}$), namely the parallel connection of C_3 and G_1 . This circuit (Fig. 7b) has the similar properties. The zeros are staying on the imaginary axis, or factor $Q_N \rightarrow \infty$, if the desired condition $C_2 = C_2 + C_3$ is valid. Then the transfer function is given by

$$K(s) = \frac{s^2 C_1 C_2 + G_1 G_2}{s^2 C_2^2 + s C_2 G_1 + G_1 G_2}, \quad (31)$$

and the design equations are

$$\omega_p = \frac{1}{C_2} \sqrt{\frac{1}{R_1 R_2}}, \quad \omega_N = \omega_p \sqrt{\frac{C_2}{C_1}}, \quad (32), (33)$$

$$Q_P = 2\sqrt{\frac{R_1}{R_2}}, \quad Q_N \rightarrow \infty. \quad (34), (35)$$

The other *variant LPN-3* is shown in Fig. 7c. This variant is based on the general structure GBS-5. There the desired $Q_N \rightarrow \infty$ requires the condition $G_3 = G_2 = G$ and then the transfer function is

$$K(s) = \frac{s^2 C_1 C_2 G_1 + G^2 G_1}{s^2 C_1 C_2 (G_1 + 2G) + s C_1 G (G_1 + G) + G^2 G_1}. \quad (36)$$

By this way the biquad LPN-3 (Fig. 7c) can be designed using the following, little complicated, equations

$$\omega_p = \frac{1}{R\sqrt{C_1 C_2 \left(1 + \frac{2R_1}{R}\right)}}, \quad \omega_N = \omega_p \sqrt{1 + \frac{2R_1}{R}}, \quad (37), (38)$$

$$Q_P = \sqrt{\frac{C_2}{C_1}} \sqrt{1 - \left(\frac{R_1}{R + R_1}\right)^2}, \quad Q_N \rightarrow \infty. \quad (39), (40)$$

The last variant of the *LPN-4* (Fig. 7d) is based on the general structure GBS-6, adding in the branch with the C_2 in the LPN-3 (Fig. 7c) a voltage follower (VCVS, with the gain $A = 1$). In this case the transfer function (36) is modified in

$$K(s) = \frac{s^2 C_1 C_2 G_1 + G^2 G_1}{s^2 C_1 C_2 (G_1 + G) + s C_1 G (G_1 + G) + G^2 G_1}. \quad (41)$$

and then the design equations are

$$\omega_p = \frac{1}{R\sqrt{C_1 C_2 \left(1 + \frac{R_1}{R}\right)}}, \quad \omega_N = \omega_p \sqrt{1 + \frac{R_1}{R}}, \quad (42), (43)$$

$$Q_P = \sqrt{\frac{C_2}{C_1}} \sqrt{\frac{R_1}{R + R_1}}, \quad Q_N \rightarrow \infty. \quad (44), (45)$$

10. High-Pass Notch Biquad with NIC

The high-pass notch biquads (HPN's) are dual to the LPN's and can be obtained from Fig. 7 replacing $R_k \leftrightarrow C_k$. The resulting circuit diagrams are shown in Fig. 8.

The *variant HPN-1* is also given from the *BR-2* (Fig. 6b) adding one other resistor ($Y_4 = G_3$), as shown in Fig. 8a. Assuming the acceptable condition $C_1 = C_2 = C$, the HPN-1 (Fig. 8a) holds the transfer function

$$K(s) = \frac{s^2 C^2 + G_1 G_2}{s^2 C^2 + s G_1 C + G_1 (G_2 + G_3)}, \quad (46)$$

and the following design equations

$$\omega_p = \frac{1}{C} \sqrt{G_1 (G_2 + G_3)}, \quad \omega_N = \omega_p \sqrt{\frac{G_2}{G_2 + G_3}}, \quad (47), (48)$$

$$Q_P = \sqrt{\frac{G_2}{G_2 + G_3}}, \quad Q_N \rightarrow \infty. \quad (49), (50)$$

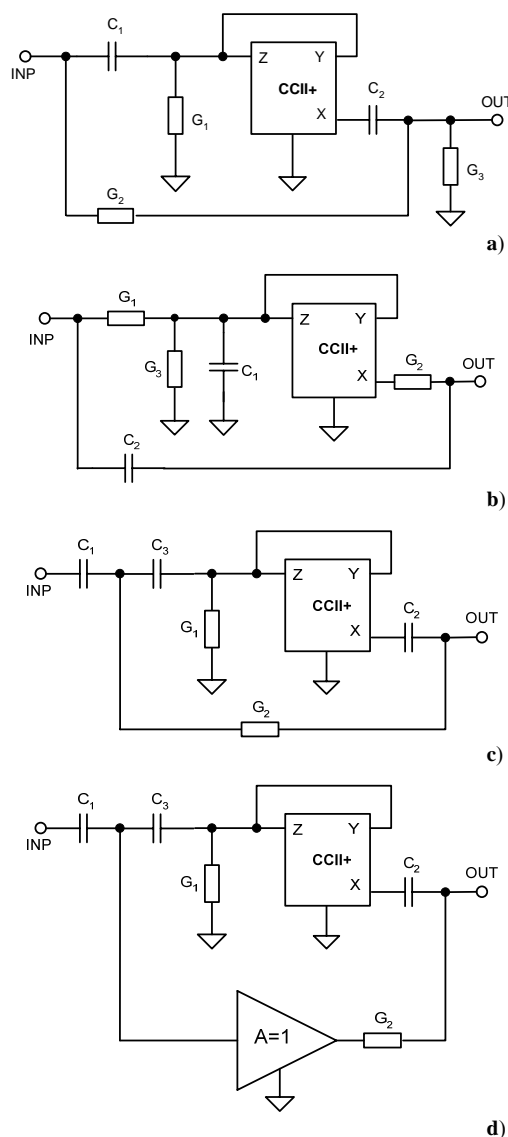

Fig. 8. High-pass notch biquad based on the NIC: a) variant HPN-1, b) variant HPN-2, c) variant HPN-3, d) variant HPN-4.

To obtain the desired parameter $Q_{N \rightarrow \infty}$ in the *variant HPN-2* (Fig. 8b) it is required $G_2=G_1-G_3$. Then

$$K(s) = \frac{s^2 C_1 C_2 + G_1 G_2}{s^2 C_1 C_2 + s C_1 G_2 + G_2^3}, \quad (51)$$

and the design equations are

$$\omega_p = \frac{G_2}{\sqrt{C_1 C_2}}, \quad \omega_N = \omega_p \sqrt{\frac{G_1}{G_1 + G_3}}, \quad (52), (53)$$

$$Q_p = \sqrt{\frac{C_2}{C_1}}, \quad Q_N \rightarrow \infty. \quad (54), (55)$$

For the *variant HPN-3* (Fig. 8c) the acceptable condition is $C_2=C_3=C$ and then the transfer function has the following form

$$K(s) = \frac{s^2 C^2 + G_1 G_2}{s^2 C^2 + s C G_1 \left(1 + \frac{C}{C_1}\right) + G_1 G_2 \left(1 + \frac{2C}{C_1}\right)}, \quad (56)$$

and the design equations are

$$\omega_p = \frac{1}{C} \sqrt{\frac{1 + \frac{2C}{C_1}}{R_1 R_2}}, \quad \omega_N = \frac{\omega_p}{\sqrt{1 + \frac{2C}{C_1}}}, \quad (57), (58)$$

$$Q_p = \sqrt{\frac{G_2}{G_1}} \sqrt{1 - \left(\frac{C}{C + C_1}\right)^2}, \quad Q_N \rightarrow \infty. \quad (59), (60)$$

The last *variant HPN-4* (Fig. 8d) is based on the general structure GBS-6 (Fig. 2d) with the voltage follower in one branch. Then the transfer function (56) and the design equations are modified in

$$K(s) = \frac{s^2 C^2 + G_1 G_2}{s^2 C^2 + s C G_1 \left(1 + \frac{C}{C_1}\right) + G_1 G_2 \left(1 + \frac{C}{C_1}\right)}, \quad (61)$$

$$\omega_p = \frac{1}{C} \sqrt{\frac{1 + \frac{C}{C_1}}{R_1 R_2}}, \quad \omega_N = \frac{\omega_p}{\sqrt{1 + \frac{C}{C_1}}}, \quad (62), (63)$$

$$Q_p = \sqrt{\frac{R_1}{R_2}} \frac{1}{\sqrt{1 + \frac{C}{C_1}}}, \quad Q_N \rightarrow \infty. \quad (64), (65)$$

Using these formulas we can design all types of notch biquads, namely the LP-N, HP-N and the BR, too. A handicap of these simple circuits with a single CC II is impossibility in arbitrary value setting and some proportion between f_p/f_n and Q_p .

11. All-Pass Biquad Using NIC

The all-pass (APF) is a special type of the biquad, whose magnitude response is constant, but the phase is linearly frequency-dependent and/or the group delay is

constant in some frequency range [7]. The classical implementation of the APF biquad using standard opamp is well known, nevertheless such a network can be implemented by our NIC, too.

The APF biquad can be obtained from the BR biquad given above in Fig. 6, both variants BR-1 or BR-2, taking other design conditions. The zeros in the left half-plane must be mirroring the poles. Namely for the BR-1, the following condition must be valid

$$C_2(G_1 - G_2) = -\frac{C_1 G_2}{2}. \quad (66)$$

Then the natural frequency and quality factor of the zeros and poles have the same values, given by following equations

$$\omega_N = \omega_p = \sqrt{\frac{G_1 G_2}{C_1 C_2}}, \quad Q_p = Q_N = 2 \sqrt{\frac{G_1 C_2}{C_1 G_2}}. \quad (67), (68)$$

Defining the component ratios

$$m = \frac{C_2}{C_1}, \quad n = \frac{R_1}{R_2}, \quad (69)$$

then

$$Q_N = Q_p = 2 \cdot \sqrt{\frac{m}{n}}, \quad (70)$$

and the design way can be noted as

$$C_1 = C, \quad C_2 = m \cdot C, \quad R_2 = R, \quad R_1 = nR, \quad (71)$$

$$n = \frac{2}{Q_p^2} + 1, \quad m = \frac{n}{2(n-1)}. \quad (72), (73)$$

12. Realization and Simulation

To evaluate the performance of the structures given above, a practical band-pass filter based on the BP-2 biquad (Fig. 5b) was designed with the commercially available components. The main functional block, which is the CC II (+), was realized by the input part (x, y, z) of the commercially available current feedback amplifier AD 844. The basic circuit diagram from Fig. 5b was ingeniously supplemented by electronic tuning, based on the bootstrap principle. The analogue multiplier MLT 04 provides a variable resistor in Fig. 9, namely grounded G_2 (Fig. 5b), what is simpler and floating G_2 (Fig. 5b), what needs supplementary adders using TL072. The proposed circuit in Fig. 9 was simulated with PSpice using professional macro models and experimentally tested. The resulting measured magnitude responses (Fig. 10) have confirmed the symmetrical analysis and theoretical assumptions.

13. Conclusion

The given structures based on the negative impedance converter implemented by the single classical three-port current conveyor CC II with connected ports Y-Z is really the right choice to design basic and notch ARC biquads.

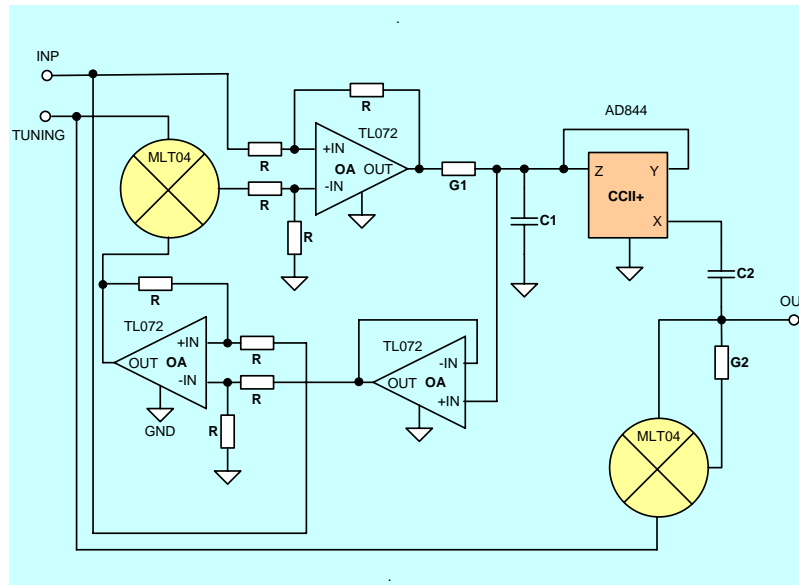

Fig. 9. Realization of the BP biquad (Fig. 5).

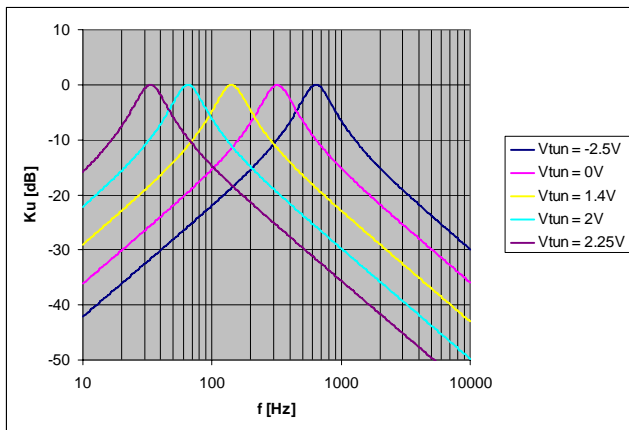

Fig. 10. Magnitude responses of the the BP biquad (Fig. 9).

These circuits need prevalingly one functional block only (the structure GBS-6 two) and maximally five passive elements. One single CC II means smaller chip area, lower power consumption and lower noise. The proposed biquads are expected to be used in elliptic filters at higher ranges.

Acknowledgements

The research described in the paper was financially supported by the Czech Ministry of Education under the research program MSM 0021630513.

References

[1] SEDRA, A. S., SMITH, K. C. A second generation current conveyor and its applications. *IEEE Transaction on Circuit Theory*, vol. CT-17, Feb. 1970, p. 132-134.

[2] SVOBODA, J. A., MCGORY, L., WEBB, S. Applications of commercially available current conveyor. *International Journal of Electronics*, 1991, vol. 70, no.1, p. 159-164.

[3] SUN, Y., FIDLER, J. K. Versatile active biquad based on second-

generation current conveyors. *International Journal of Electronics*, 1994, vol. 76, p. 91-98.

[4] DOSTÁL, T., ČAJKA, J., VRBA, K. Design procedure of oscillators and biquads based on current conveyors. In *Proceeding of 8th WSEAS International Conference on Circuits and Systems CSCC 04*. Athens (Greece), 2004, sec. 487, paper 215, 4.

[5] CELMA, S., MARTINEZ, P. A., CARLOSENA, A. Approach to synthesis of canonic RC-active oscillators using CC II. *IEE Proceeding of Circuits Devices and Systems*, 1994, vol. 141, no. 6, p. 493-497.

[6] FERRI, G., GUERRINI, N.C. *Low-Voltage Low-Power CMOS Current Conveyors*. Kluwer Academic Publishers, Boston, 2003.

[7] TOUMAZOU, C., LIDGEY, E. J., HAIGH, D. G. *Analogue IC Design: The Current Mode Approach*. Peter Peregrinus Ltd., London, 1990.

[8] CHEN, W. K. *The Circuits and Filters Handbook*. CRC Press, Florida, 1995.

[9] DOSTÁL, T., AXMAN, V. Current conveyor CC II with connected ports Y-Z. In *Proceeding of 17th International Conference Radioelektronika 2007*. Brno (Czech Republic), 2007, p. 47-50.

About Author...

Tomáš DOSTÁL (*1943) received his Ph.D (1976) and Dr.Sc. degree (1989) from the Brno University of Technology. He was with the Military Academy Brno (1976-1978 and 1980-1984) and with the Military Technical College Baghdad (1978-1980). Since 1984 he has been with the Brno University of Technology as Professor of Radio-Electronics. His interests are in circuit theory, analogue filters, switched capacitor networks and circuits in the current mode.

Vladimír AXMAN (*1977) received his Ing. degree (2000) from the Brno University of Technology. He is with ST Microelectronics as design layout engineer. His interests are in analogue and mixed circuits and filters.