

Fig. 7. Current-source configuration used to obtain a dynamically matched 1:5 bias current ratio for generating  $\Delta V_{BE}$ .

matching cannot be expected from precise layout alone. Therefore, **dynamic element matching is used to average out mismatches.**

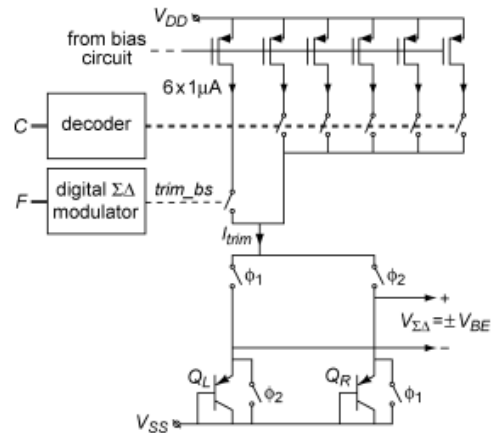

Fig. 8. Current-source configuration used to obtain a trimmable bias current  $I_{trim}$  for generating  $V_{BE}$ .

