

AC Analysis of Idealized Switched-Capacitor Circuits in Spice-Compatible Programs

DALIBOR BIOLEK¹, VIERA BIOLKOVA², ZDENEK KOLKA²

Depts. of Microelectronics¹ and Radioelectronics², Brno University of Technology

Dept. of EE¹, University of Defence, Brno, Czech Republic

dalibor.biolek@unob.cz <http://user.unob.cz/biolek>

Abstract: Direct AC analysis of idealized switched-capacitor circuits in Spice-compatible programs is described in the paper. The capacitor is described by a special macro-circuit, whose mathematical model is based on modified z -domain charge equations and on the theory of equivalent signals.

Keywords: - switched capacitor, analysis, SPICE.

1 Introduction

Their inability of direct small-signal AC analysis of switched-capacitor (SC) and switched-current (SI) circuits belongs to well-known limitations of Spice-compatible programs. The only universal method, which is very laborious and time consuming indeed, consists in the steady state transient analysis with the input signal swept by a harmonic signal of a given frequency, the selection of an AC component of output signal, and its comparison with the input. This procedure must be repeated for more frequencies. A certain degree of automation of such actions in the WinSpice (SPICE3) program is described in [1]. This method uses a multi-tone excitation of the switched circuit. The corresponding complex transfers are then determined via spectral analysis. Another method is described in [2]. The z -domain equivalent circuit is modeled in the continuous-time domain using the lossless transmission line element to implement the required one-port storage element (storistor). The method is restricted to those SC networks where the effects of nonideal OpAmps can be neglected [2].

The utilization of direct Spice-like AC analysis cannot be performed here because it starts from the circuit linearization around the DC operating point. However, the operating point of switched circuit is periodically swept by virtue of the switching signal.

A number of algorithms for gaining the above frequency responses directly and with much less computational effort are described in the literature [3], [4]. However, these procedures are not compatible with mathematical algorithms, implemented in the SPICE-family programs. That is why they were used on the platform of special analysis programs. Such programs can solve switched circuits, consisting of ideal

capacitors, ideal switches with zero on-resistances and zero off-conductances, and ideal controlled sources. Also some real properties of circuit elements can be modeled. Most of such methods are based on so-called charge equations. After applying the z -transform, they lead to discrete-time equivalent models of switched circuit. The frequency responses can be obtained after the well-known substitution $z = \exp(j\omega T_S)$, where T_S is the switching period. Other special methods, which are appropriate for modeling the AC behavior of general linear circuits with periodically controlled switches, e.g. the method of generalized transfer functions (GTF) [5], can be applied in SPICE only for unified simple blocks, for which the GTF is determined analytically and then it is modeled using the means of behavioral modeling [6].

A direct AC analysis of idealized two-phase SC circuits in Spice-compatible programs is described below. The frequency responses are not obtained via repeated transient analysis or by the method of multi-tone excitation, but by the conventional Spice-like AC analysis of a specially made-up model of switched circuit. The user must create a double circuit, taking into account the configuration of switches in both switching phases. This procedure is time-saving thanks to special models of capacitors which reflect the interlacing of their behavior between the switching phases. The method can be easily extended to multi-phase switching. However, making-up such models would be rather laborious in the SPICE environment. It is also determined by limited SPICE features in generating more complicated netlists via conventional PSpice template [7].

The method can be also partially extended to Spice modeling of real properties of circuit elements, e.g. switch resistances or OpAmp bandwidth. More details can be found in [8].

2 Behavioral SPICE model of capacitor in ideal SC circuit

Consider the switched capacitor in Fig. 1 (a). The number 1 or 2 at the switch denotes the switching phase in which this switch is on. The switching diagram together with the sketch of the capacitor voltage waveform is in Fig. 1 (b). Note that the so-called inconsistent initial conditions [9] can appear in the circuit due to ideal switch models, which result in the discontinuous recharging of capacitors by currents in the form of Dirac impulses. That is why one should expect discontinuities in capacitor voltages. It is necessary to discriminate between the left-side and the right-side limits at instances when the switches change their states.

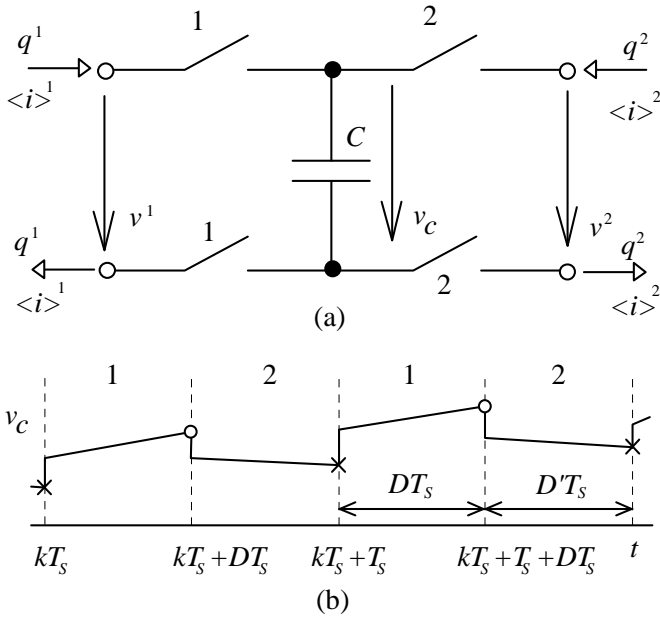

Fig. 1: (a) Switched capacitor, (b) switching diagram with marked limit values of capacitor voltage at the ends of switching phases 1 (o) and 2 (x). $D \in (0,1)$ is the duty ratio, $D' = 1 - D$.

The following charge equations are true for the circuit in Fig. 1:

$$q^1(kT_s + DT_s) = C[v^1(kT_s + DT_s^-) - v^2(kT_s^-)],$$

$$q^2(kT_s + T_s) = C[v^2(kT_s + T_s^-) - v^1(kT_s + DT_s^-)].$$

Here q^1 (q^2) are the differences of electric charge on the capacitor within the time intervals from the ends of switching phases 2 to the ends of switching phases 1 (from the ends of switching phases 1 to the ends of switching phases 2). The superscripts $-$ denote the left-side limits of the corresponding circuit variables.

The charge equations can be transferred into the current equations, which can be already implemented in Spice:

$$\langle i \rangle^1 = \frac{C}{T_s} [v^1(kT_s + DT_s^-) - v^2(kT_s^-)], \quad (1)$$

$$\langle i \rangle^2 = \frac{C}{T_s} [v^2(kT_s + T_s^-) - v^1(kT_s + DT_s^-)],$$

where $\langle i \rangle^1$ and $\langle i \rangle^2$ are the average values of capacitor current in switching phases 1 and 2, averaged over the entire switching period:

$$\langle i \rangle^1(kT_s + DT_s) = \frac{1}{T_s} \int_{kT_s}^{kT_s + DT_s} i(t) dt = \frac{q^1(kT_s + DT_s)}{T_s}$$

$$\langle i \rangle^2(kT_s + T_s) = \frac{1}{T_s} \int_{kT_s + DT_s}^{kT_s + T_s} i(t) dt = \frac{q^2(kT_s + T_s)}{T_s}.$$

For the purpose of the AC analysis of the switched circuit whose part is the switched capacitor in Fig. 1, consider the periodic steady state in the circuit due to harmonic input signal e^{st} , $s = j\omega$. It can be shown that each signal in the switched circuit can be approximated by the so-called equivalent signal, which is also of harmonic nature with the identical repeating frequency ω [5]. More concretely, the equivalent signal $v^{1e} = \hat{V}^1 e^{st}$, where \hat{V}^1 is the complex phasor of this signal, can be interleaved with the „o“ points in Fig. 1 (b), which correspond to the ends of phases 1 in the sense of the left-side limits. Similarly, the equivalent harmonic signal $v^{2e} = \hat{V}^2 e^{st}$ is interleaved with the „x“ points. Then Eq. (1) can be rewritten via these equivalent signals. Simple arrangements yield:

$$\hat{I}^1 = \frac{C}{T_s} [\hat{V}^1 - \hat{V}^2 z^{-D}], \quad \hat{I}^2 = \frac{C}{T_s} [\hat{V}^2 - \hat{V}^1 z^{-D'}], \quad (2)$$

where the phasors of equivalent currents in switching phases 1 and 2 are on the left sides of equations, and z is the well-known operator of the z transform, with $z = \exp(st_s)$.

The behavioral model of the capacitor in Fig. 2 for switching phases 1 and 2 is made up on the basis of Eqs. (2). This model can be directly implemented as a Spice subcircuit. The controlled sources in the model may be implemented via Laplace sources, utilizing the above substitution $z = \exp(st_s)$. The model is valid both for the switched and the “fixed” capacitor.

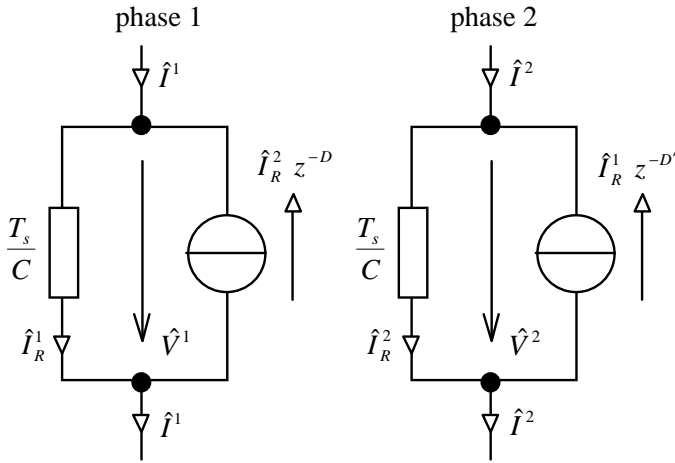

Fig. 2: AC model of the capacitor in SC circuit.

3 Modeling of other circuit elements in SC circuits

Capacitors, ideal switches, and ideal voltage-controlled voltage sources (VCVSs) for the modeling of voltage amplifiers including OpAmps are typical circuit elements in idealized SC circuits. The VCVSs represent only the non-inertial transformation of gate voltages. That is why the mathematical model of VCVS can be used independently in both switching phases.

Modeling of other circuit elements beyond the frame of idealized SC circuits can be problematic in Spice-compatible programs. For example, resistors for modeling nonzero on-resistances of switches introduce considerable time constants of transient phenomena. Then the voltage drops on them at the ends of switching phases cannot be neglected as is the case in the circuit in Fig. 1 (a). However, these voltages do not depend on average currents in Eqs. (1) and (2), but on the currents at the ends of switching phases.. The relation between averaged and instantaneous currents depends on the type of transient phenomenon and thus on the total circuit configuration. As a result, the switch equations would depend not only on this switch, but also on the remaining parts of the circuit. This involvement can be satisfactorily solved in Spice only by trade-off modeling. A similar problem appears, for example, when modeling the frequency-dependent gain of the operational amplifier. Details can be found in [9].

4 Demonstration of AC analysis

Consider the switched-capacitor biquad in Fig. 3 according to [10]. This filter is designed for a switching frequency of 6MHz. Its center frequency is

400kHz with a quality factor of 10. The S-H circuit at the input samples the signal in phases 1 and holds them during the whole switching periods.

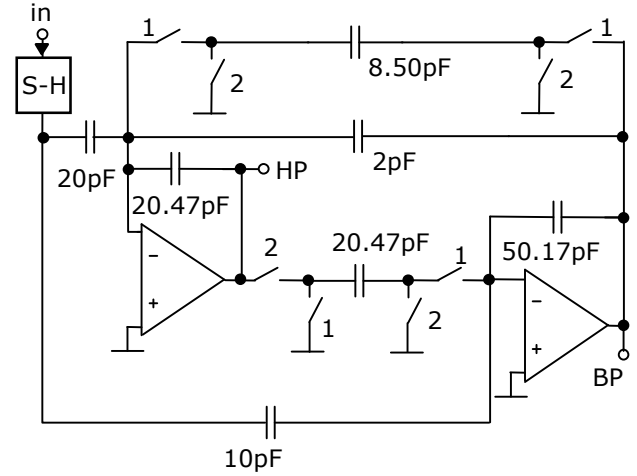

Fig. 3: Switched-capacitor biquad [10].

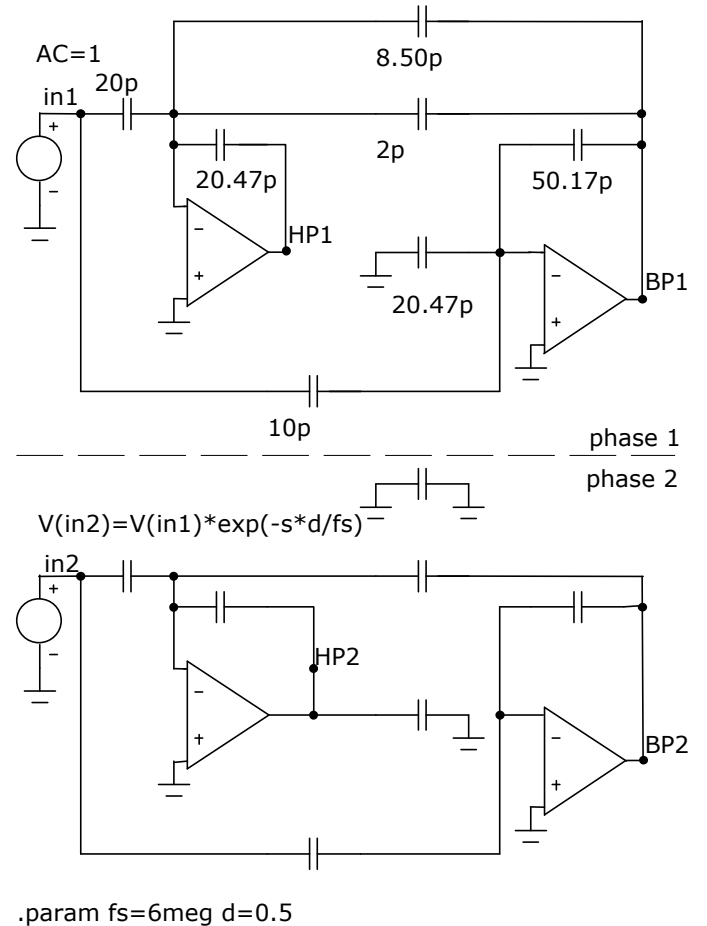

Fig. 4: Spice modeling of filter from Fig. 3 for subsequent AC analysis.

A demonstration of the filter model in the schematic editor of Spice-compatible program Micro-Cap 9 is shown in Fig. 4. The schematic symbols of capacitors

are duplicated for both switching phases, representing Spice subcircuits which model equations (2) on the basis of the substitution diagram in Fig. 2. In order to make the circuit creation more comfortable, the schematic symbol of the ideal OpAmp is also duplicated. The Opamp is modeled by an ideal VCVS with adequately large voltage gain. The influence of S-H circuit is modeled by the voltage source, connected to the node "in2".

The AC analysis results in Fig. 5 fully correspond to the results in [10].

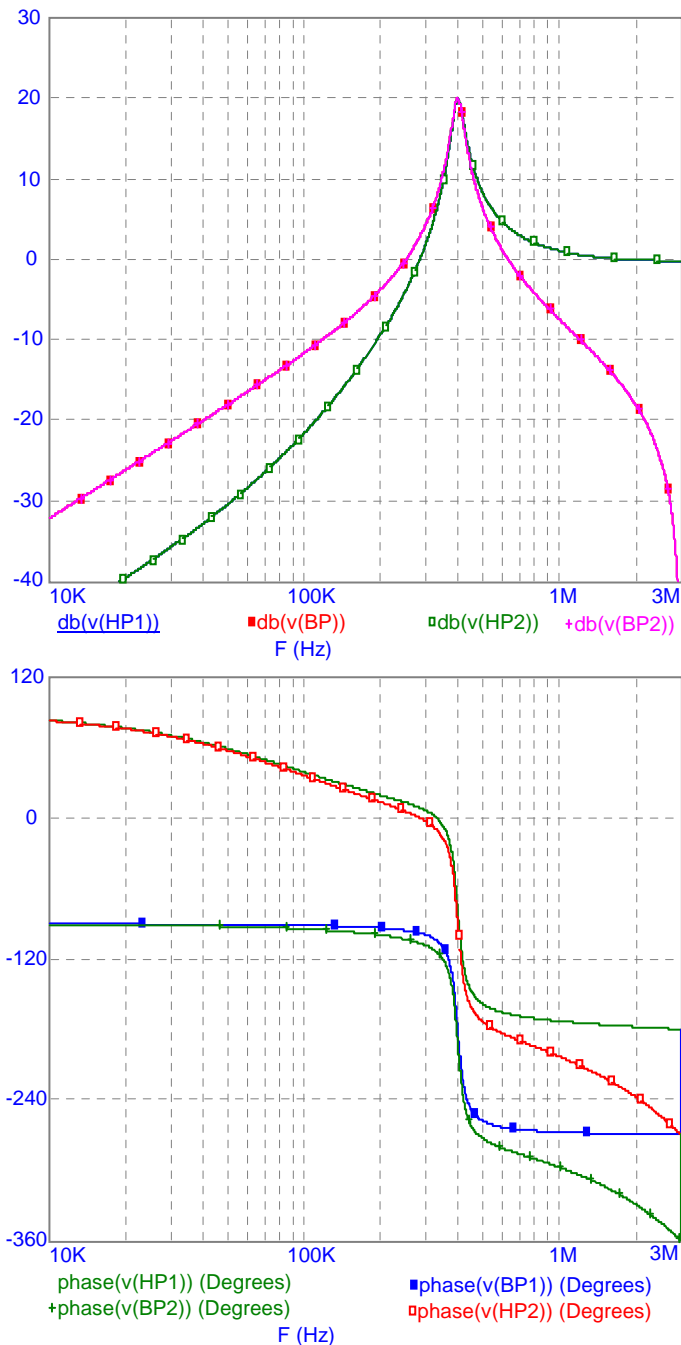

Fig. 5: AC analysis of filter from Fig. 3 by Micro-Cap program.

5 Conclusions

The paper describes a modification of the method of charge equations for modeling idealized two-phase switched-capacitor circuits. The above modification is based on the theory of equivalent signals and on the transformation of charge equations into current equations. The switched capacitor is then described by gate voltages and averaged gate currents, which is the first assumption of successful implementation in SPICE-compatible programs. Each capacitor in the circuit is represented by a pair of models for switching phases 1 and 2. The graphic representation of such models, the double schematic symbol, facilitates making up the model of switched-capacitor circuit in the schematic editor.

In principle, an extension of this method to circuits with multi-phase switching is possible. However, it would pose some practical problems in the environment of most Spice-compatible programs. A trade-off Spice analysis should be also applied for real switched-capacitor circuits [8].

Acknowledgment

This work is supported by the Grant Agency of the Czech Republic under grants No. 102/05/0771 and 102/05/0277, and by the research programmes of BUT MSM0021630503, MSM0021630513, and UD Brno MO FVT0000403.

References

- [1] Bičák, J., Hospodka, J. 'Frequency response of switched circuits in SPICE'. Proceedings of ECCTD'03, Krakow, IEEE, 2003, pp. I-333-336.
- [2] Nelin, B.D. 'Analysis of Switched-Capacitor Networks Using General-Purpose Circuit Simulation Programs', IEEE Trans. On CAS, Vol. 30, No. 1, January 1983, pp. 43-48.
- [3] Unbehauen, R., Cichocki, A. 'MOS switched-capacitor and continuous-time integrated circuits and systems'. Springer-Verlag, 1989.
- [4] Vlach, J., Singhal, K. 'Computer Methods for Circuit Analysis and Design'. Van Nostrand Reinhold Company, New York, 1987.

- [5] Biolek, D. 'Modeling of Periodically Switched Networks by Mixed s-z Description', IEEE Trans. on CAS-I, Vol. 44, No. 8, August 1997, pp. 750-758.
- [6] Biolek, D., Biolková, V., Dobeš, J. 'Modeling of switched DC-DC converters by mixed s-z description'. IEEE Int. Symp. on Circuits and Systems, ISCAS2006, Greece, Kos, 2006, pp. 831 – 834.
- [7] PSpice A/D Reference Guide. Product version 15.7. Cadence, July 2006.
- [8] Biolek, D., Biolková, V. 'SPICE analysis of real switched-capacitor networks'. Submitted to the 14th IEEE Int. Conference on Electronics, Circuits and Systems (ICECS 2007), Dec. 11-14, 2007, Marrakech, Morocco.
- [9] Wojciechowski, J., Vlach, J., Opal, A. 'Analysis of Nonlinear Networks with Inconsistent Initial Conditions'. IEEE Transactions on CAS-I, 1995, vol. 42, no. 4, p. 195-200.
- [10] Dolívka, L., Hospodka, J. 'Switched-Capacitor Filter Optimization with Respect to Switch On-State Resistance and Features of Real Operational Amplifiers'. Radioengineering, Vol. 16, No. 2, July 2007, pp. 34-39.